



DIAMONDBACK

DiamondBackCovers.com / 800 935 4002

DIAMONDBACK TOOLBAR

INSTALLATION GUIDE

DP-1









15 minutes
Normal install time

Keep an eye out for these icons:

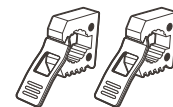
IMPORTANT!
Important installation information

Helpful Hints
Tips to assist installation

PARTS INCLUDED:

	Installation Hardware	Tool Mounting Hardware
 ToolBar	 10-32x3/4" Button Head Screws (4)	 1/4-20 x 3/4" Bolts (2)
	 Quickfist Clamps (2)	 1/4-20 Mounting Nuts (3)  10-24 Mounting Nuts (3)
	 10-32 Rubber Well Nuts (4)	 10-24x1" Bolts (2)
	 Quickfist Clamp Washers (2)	 10-24x1" Flat Head Screws (2)

TOOLS REQUIRED:



Drill



1/8" Bit



3/8" Bit



1/8" Hex Key
(One came with your cover)



Marking Utensil
(A Silver/Black marker is our favorite)



Tape Measure
(optional)

INSTRUCTIONS

- Determine where you would like to mount the ToolBar. One of our favorite locations is centered on one of the structural studs of the DiamondBack Cover.
 - The ToolBar may need to be trimmed if installing in a location shorter than 42". Trimming may be required on Ram Box covers and some covers with Side Boxes or in the path of gas spring.
- Open the desired panel and pull the gas spring off the access panel ball stud by flipping the quick-release tab outward to the open position. If necessary, disengage the safety catch.
 - If you disengage the safety catch, be sure to reattach properly.
- Fold this panel all the way over and rest on the opposite panel. This allows for a nice flat workspace.
 - If you have a top-mounted accessory that prevents the panel from being folded completely over, this process can be completed with the cover closed or in the open position.

- Place the ToolBar in the desired location and mark the 4 mounting holes.
- Place the ToolBar off to the side and drill a pilot hole at each of the marks with a 1/8" drill bit.
- Enlarge the holes using a 3/8" drill bit.
 - Do not use a step bit or ream the hole out after drilling. It needs to be exactly 3/8" or slightly smaller.
- Once the holes are drilled, locate 4 of the rubber well nuts. Place one of these in each of the drilled holes.
 - Well nuts have a grip range of 0.015" - 0.188". Do not mount ToolBar using the well nuts on material outside of this thickness.

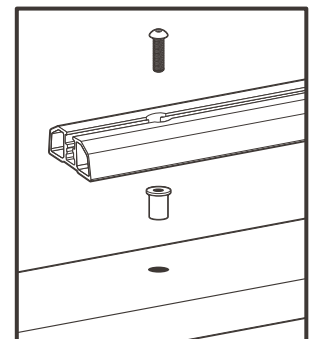

INSTRUCTIONS (CONTINUED)

- 8** Place the ToolBar on top of these well nuts and align your holes.

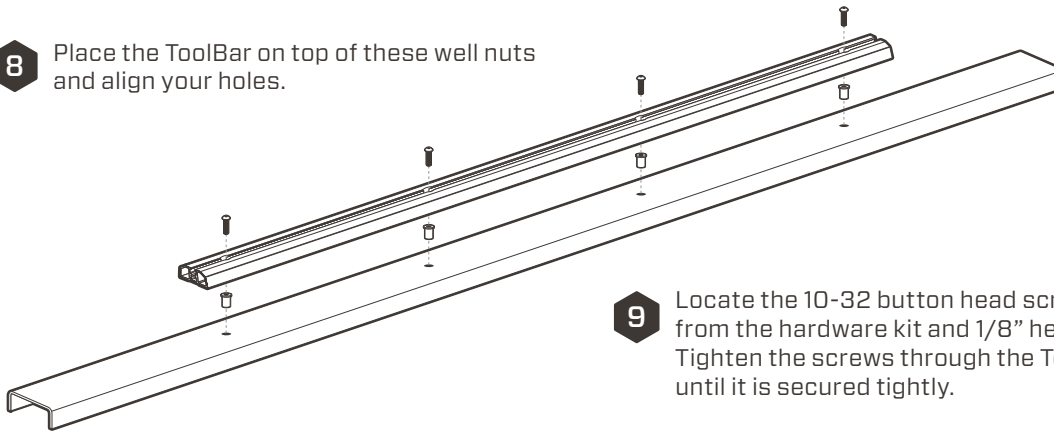

- 9** Locate the 10-32 button head screws from the hardware kit and 1/8" hex key. Tighten the screws through the ToolBar until it is secured tightly.

- !** Allow the screws to pull the ToolBar into the well nuts. If too much pressure is placed directly on the well nut before it has begun forming, the well nut may push through the mounting surface.

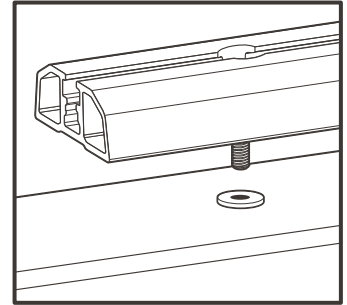

QUICK FIST CLAMPS

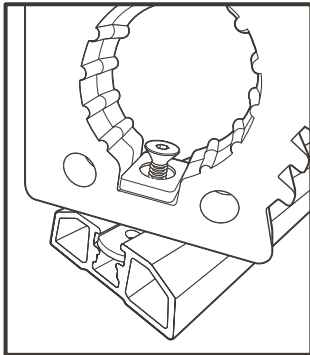

Locate the included #10-24 flat head screw and #10-24 mounting nut from the hardware kit. Insert screw into the plastic washer and Quick Fist clamp. Partially thread the mounting nut onto the screw. Slide the mounting nut into the end of the ToolBar and tighten the screw at the desired location.

TOOL MOUNTING HARDWARE

- ★ Beyond the standard clamp hardware included with your Toolbar, the additional hardware is provided help you mount a variety of other clamps and tools. It is a baseline to help you get started.