



DIAMONDBACK

Most Trucks with Bed Wall Tracks / Cargo Management Systems

270

INSTALLATION GUIDE

CVR-270.3

60 minutes
Normal install time

Keep an eye out for these icons:

IMPORTANT!
Important installation information

Helpful Hints
Tips to assist installation

PARTS INCLUDED:

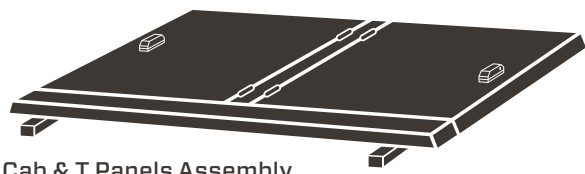

Cab & T Panels Assembly



Tail Panel

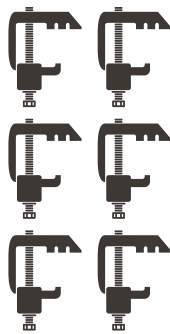

Cap Clamps (6)
exact appearance varies

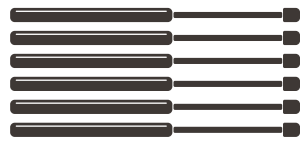

Gas Springs (6)



1/8" Hex Key

TOOLS REQUIRED:



Ratchet Wrench,
(Torque Wrench preferred)



9/16" Socket



Utility Knife



7/16" Socket

PRE-INSTALLATION NOTES (REVIEW ALL OTHER INCLUDED INSTALLATION GUIDES BEFORE BEGINNING)

Some models require bulkhead preparation first. Please refer to the instructions in the bulkhead prep kit prior to mounting the cover.

If your cover includes shims, affix the included bed rail shims first and reference their included instructions.

MOUNT THE COVER

1 Place the **cab & T panel assembly** on the front half of the bed.

2 Attach the tail panel by holding it at a 90° angle from the bed rails and mate the driver's side hinge first, followed by the passenger side's c-shaped hinge.

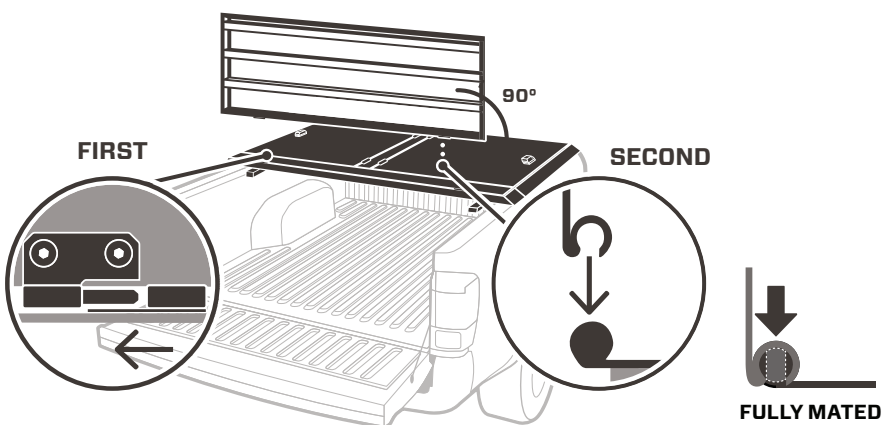

3 Position the cover front to back so that the front of the cab panels line up with the outside edge of the center of the bulkhead. Center the cover side-to-side on the truck.

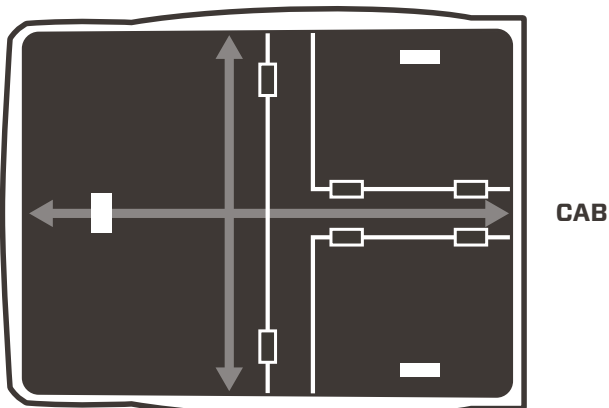

4 Secure the T panel to the truck by tightening two cap clamps under each of the three ends of the T panel. Place the clamps' bottom jaws in the track at each bedside and at the bulkhead. Uniformly tighten the cap clamps using a 9/16" socket to between **5-6 ft-lbs.**

! While tightening clamps, be aware of possible bed rail cap deformation. Overtightening clamps will damage bed rail caps and cause leaking.

! Retighten after a week of use. Check them every time you haul on top.

★ Removal of track mounted accessories can make installation smoother.

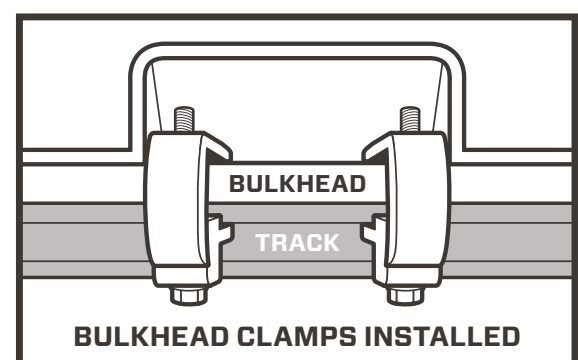
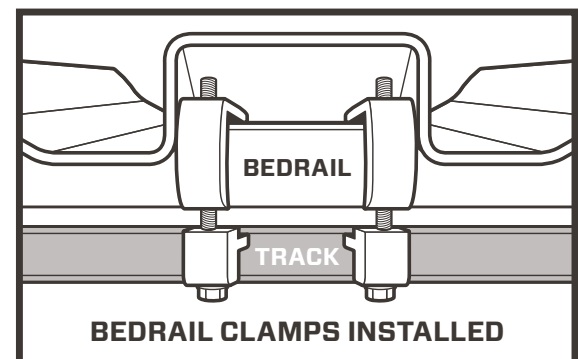

ADJUST THE LOCK RODS

5 Unbolt and move one of the bolts of the lock-rod guide brackets to the second, unoccupied slot using a 7/16" socket. Repeat this at each of the cover's bracket locations.

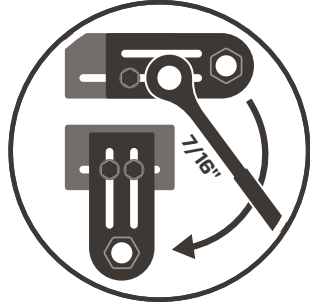

6 Loosen the set screws for the tail panel lock rods with the provided hex key and retighten each lock rod after ensuring **three things...**

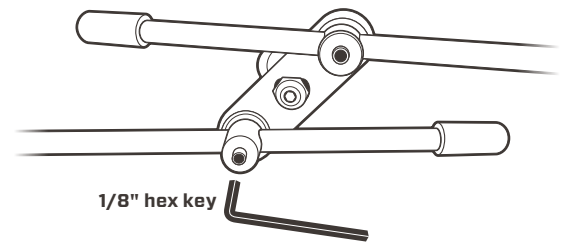

7 Loosen the set screws for the tail and cab panel lock rods with the provided hex key and retighten each lock rod after ensuring the following...

CAB PANELS:

CORRECT ORIENTATION



HANDLE OPEN

HANDLE CLOSED

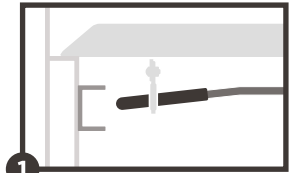

1 The angled orientation is always maintained

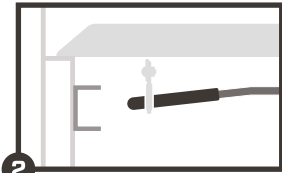

2 With the lock handle in the open position, the rod tips just clear the striker brackets.

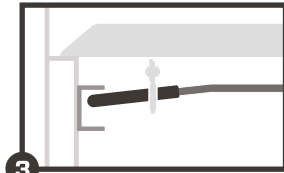

3 With the lock handle in the closed position, the lock rods are fully under the striker brackets and engaged as much as possible. Ensure the lock handle fully closes.

TAIL PANEL:

CORRECT ORIENTATION

HANDLE CLOSED



HANDLE OPEN

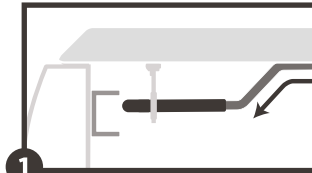

1 The Z bend orientation is always maintained

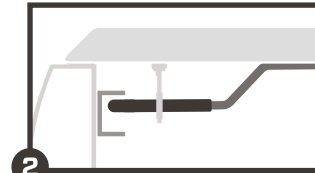

2 With the lock handle in the closed position, be sure the lock rods land inside the track and are engaged as far as possible.

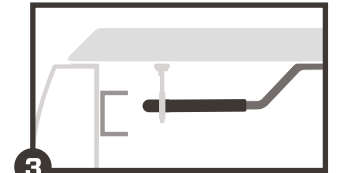

3 With the lock handle in the open position, ensure the rod tips clear the track.

8 After properly aligning the lock rods in the closed position, it is time to tighten all brackets using a 7/16" socket. To ensure a tight seal, it is crucial to simultaneously push up on the bracket AND apply downward pressure on the cover. Repeat for all bracket locations.

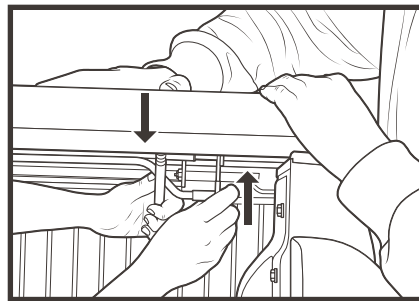

! The panels may be tough to open and close at first. Leave the panels closed as much as possible to allow the weatherstrip to break in. After a few days, you'll find things working smoothly.

! If you are also installing a bin, do so now. Refer to the bin's Installation Guide for details.

ATTACH THE GAS SPRINGS

9 Identify the 4 lighter gas springs and attach 2 to each **cab panel**.

! Make sure the barrel end is up. If you install your gas springs upside down, they'll fail.

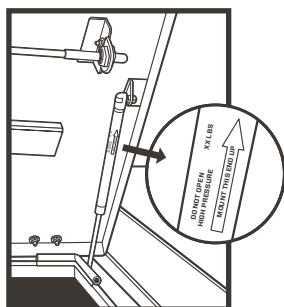

10 Attach the 2 remaining gas springs on the **tail panel**, again making sure the barrel end is up.

11 Leave the cover closed and locked for 24 hours to allow the pressure-sensitive weatherstrip adhesive to fully cure.

24 hours
Adhesive cure time

! For first 2 weeks after installation open tail panel on cover before operating tailgate.

