



DIAMONDBACK

'24-up Toyota Tacoma w/ Deck Rail System

270

INSTALLATION GUIDE

CVR-270.8

75 minutes
Normal install time

Keep an eye out for these icons:

IMPORTANT!
Important installation information

Helpful Hints
Tips to assist installation

PARTS INCLUDED:

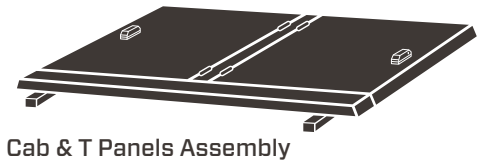

Cab & T Panels Assembly

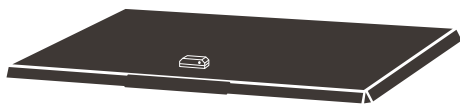

Tail Panel



Lock-Rod Striker Brackets (2)

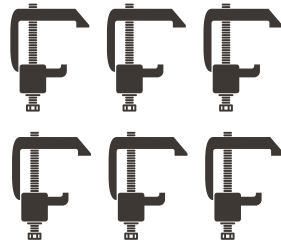

Cap Clamps (6)



1/8" Hex Key

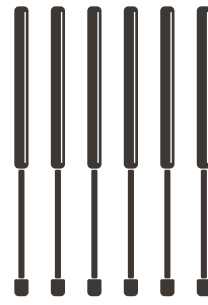

Gas Springs (6)



Ratchet Wrench,
(Torque Wrench preferred)



T30 Torx/Star Wrench



9/16" Socket



7/16" Socket

PRE-INSTALLATION NOTES (REVIEW ALL OTHER INCLUDED INSTALLATION GUIDES BEFORE BEGINNING)



TA Bulkhead Bar

This truck requires bulkhead and bed preparations. Please refer the Bed Prep Kit installation guide **PRIOR** to mounting the cover.

If you are installing a bin, refer to the bin's installation guide for details.

PREPARE CARGO BED & MOUNT PANELS

1 Remove the plastic cap from the tailgate end of the driver-side track by pressing its tab. Plastic cap will not be reused with your cover installed.

2 Use a T30 Torx wrench to remove the factory bolt near the tailgate end of the track.

★ Penetrating oil may be helpful to remove these bolts.

3 Slide the driver-side lock-rod striker bracket into the track until its corresponding hole aligns with the factory bolt. Reinsert the factory bolt and retighten it with the Torx wrench.

4 Repeat steps 1-3 on the passenger side.

5 Attach the tail panel by holding it at a 90° angle from the bed rails and begin to mate the driver's side hinge first which is slightly longer.

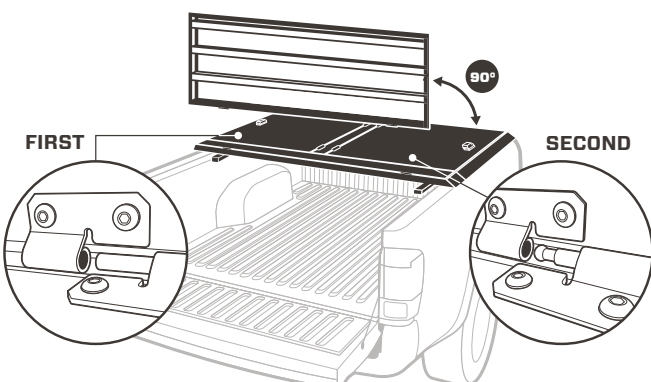

★ Mating hinges is easiest when you engage the longer pin first.

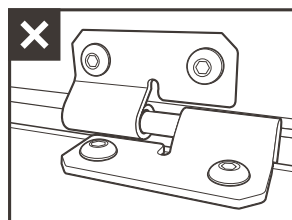

Partially mated hinge

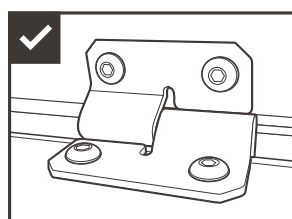

Fully mated hinge

6 Position the cover so that it lands at the point where the bulkhead bar and bedrail cap meet.

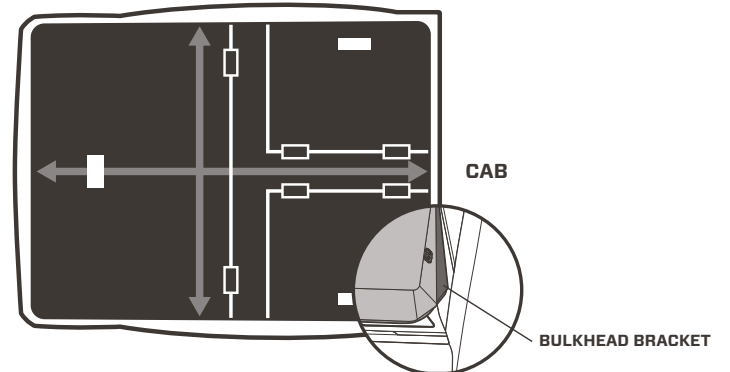

7 Secure the T-panel to the truck by tightening two cap clamps under each of the three ends of the T-panel.

Place the clamps' bottom jaws in the track at each bedside and at the bulkhead. Uniformly tighten the cap clamps using a 9/16" socket to between **4-5 ft-lbs.**

! While tightening clamps, be aware of possible bed rail cap deformation. Overtightening clamps will damage bed rail caps and cause leaking.

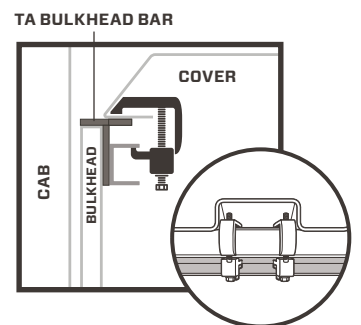

TACOMA BULKHEAD CLAMPS INSTALLED

! Retighten after a week of use. Check them every time you haul on top.

★ Removal of track mounted accessories can make installation smoother.

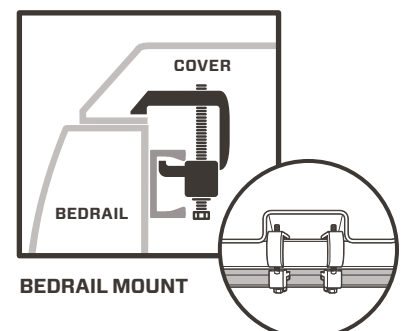

ADJUST THE LOCK RODS

8 Unbolt and move one of the bolts of the lock-rod guide brackets at the cab to the second, unoccupied slot using a 7/16" socket. Repeat this at each of the cover's bracket locations.

9 Loosen the set screws for the tail and cab panel lock rods with the provided hex key and retighten each lock rod after ensuring the following...

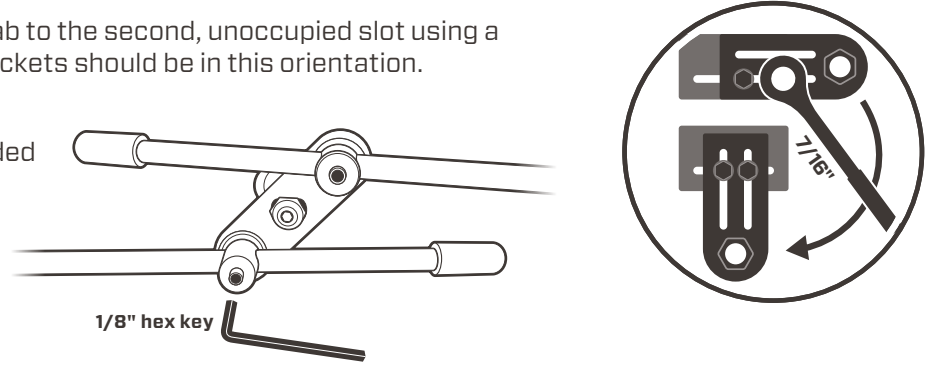

CAB PANELS:

CORRECT ORIENTATION

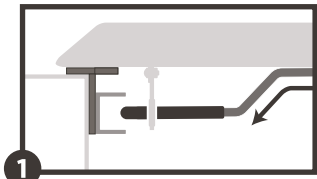

1 The Z bend orientation is always maintained.

+ HANDLE OPEN

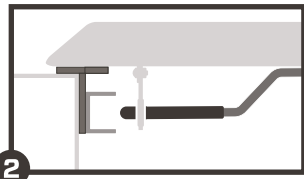

2 With the lock handle in the open position, the rod tips just clear the bulkhead bar.

▬ HANDLE CLOSED

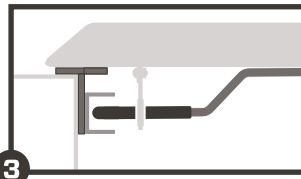

3 With the lock handle in the closed position, the lock rods are fully under the bulkhead bar and engaged as much as possible. Ensure the lock handle fully closes.

TAIL PANEL:

CORRECT ORIENTATION

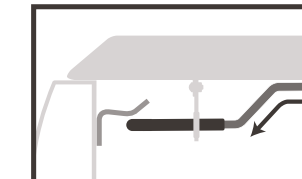

1 The Z bend orientation is always maintained

+ HANDLE OPEN

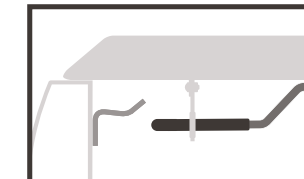

3 With the lock handle in the open position, the rod tips just clear the striker brackets.

▬ HANDLE CLOSED

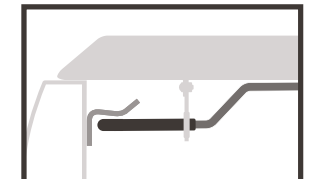

2 With the lock handle in the closed position, the lock rods are fully under the striker brackets and engaged as much as possible. Ensure the lock handle fully closes.

10 After properly aligning the lock rods in the closed position, it is time to tighten all brackets using a 7/16" socket. To ensure a tight seal, it is crucial to simultaneously push up on the bracket AND apply downward pressure on the cover. Repeat for all bracket locations.

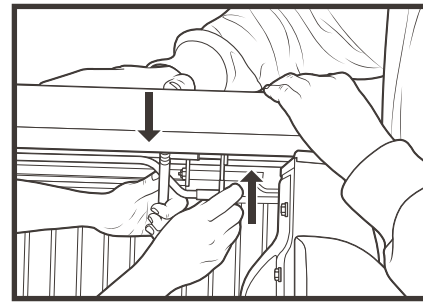

! The panels may be tough to open and close at first. Leave the panels closed as much as possible to allow the weatherstrip to break in. After a few days, you'll find things working smoothly.

ATTACH THE GAS SPRINGS

11 Identify the 4 lighter gas springs and attach 2 to each **cab panel**.

! Make sure the barrel end is up. If you install your gas springs upside down, they'll fail.

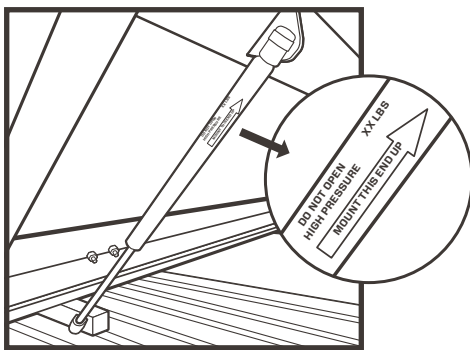
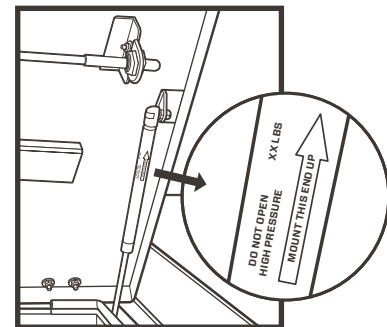

12 Attach the 2 remaining gas springs on the **tail panel**, again making sure the barrel end is up.

13 Leave the cover closed and locked for 24 hours to allow the pressure-sensitive weatherstrip adhesive to fully cure.

24 hours
Adhesive cure time

For first 2 weeks after installation
open tail panel on cover before operating tailgate.