



# DIAMONDBACK

## '05-up Toyota Tacoma with 60" Bed

# 270

# INSTALLATION GUIDE

### CVR-270.5

**75 minutes**  
Normal install time

Keep an eye out for these icons:

**IMPORTANT!**  
Important installation information

**Helpful Hints**  
Tips to assist installation

### PARTS INCLUDED:

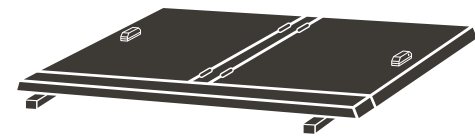

Cab & T Panels Assembly



Tail Panel



Lock-Rod Striker Brackets (2)

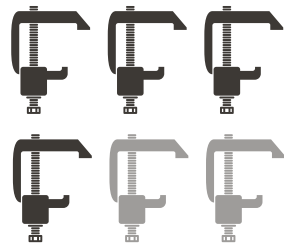

Cap Clamps  
(4) for '16-up or (6) for '05-15



1/8" Hex Key

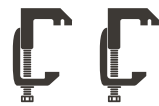

Cap Clamps  
(2) for '16-up



Gas  
Springs (6)

### TOOLS REQUIRED:

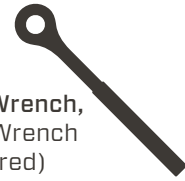

Ratchet Wrench,  
(Torque Wrench  
preferred)



T30 Torx/Star Wrench



9/16"  
Socket



7/16"  
Socket

## PRE-INSTALLATION NOTES (REVIEW ALL OTHER INCLUDED INSTALLATION GUIDES BEFORE BEGINNING)



Most trucks require the **bulkhead weatherstrip** to be installed and some require additional bulkhead preparations. Please refer to the instructions in the **Bulkhead Prep Kit** prior to mounting the cover.

If your cover includes shims, affix the included bed rail shims first and reference their included instructions.

If you are installing a bin, refer to the bin's installation guide for details.

## PREPARE CARGO BED & MOUNT PANELS

**1** Remove the plastic cap from the tailgate end of the driver-side track by pressing its tab. Plastic cap will not be reused with your cover installed.

**2** Use a T30 Torx wrench to remove the factory bolt near the tailgate end of the track.

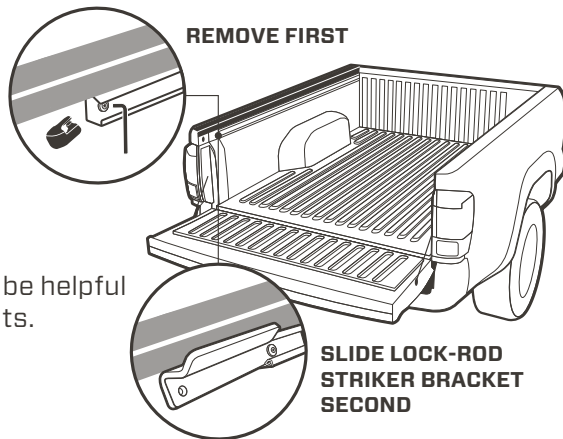

REMOVE FIRST

SLIDE LOCK-ROD STRIKER BRACKET SECOND

★ Penetrating oil may be helpful to remove these bolts.

**3** Slide the driver-side lock-rod striker bracket into the track until its forward hole aligns with the factory bolt. Reinsert the factory bolt and retighten it with the Torx wrench.

**4** Repeat steps 1-3 on the passenger side.

**5** Place the cab & T-panel assembly on the front half of the bed. Attach the tail panel by holding it at a 90° angle from the bed rails and mate the driver's side hinge first, followed by the passenger side's c-shaped hinge.

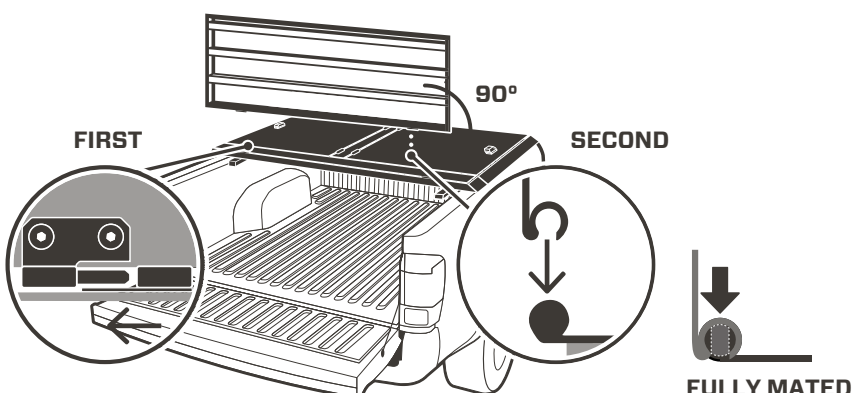

FIRST

SECOND

FULLY MATED

**6** Position the cover front to back so that the front of the cab panels line up with the outside edge of the center of the bulkhead. Center the cover side-to-side on the truck.

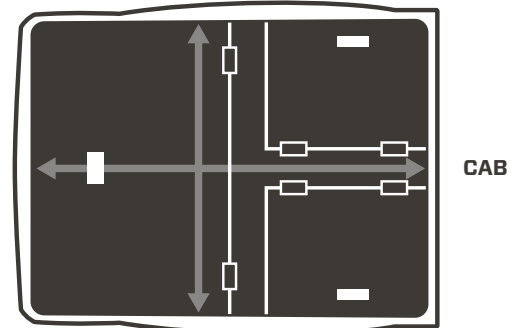

**7** Secure the T-panel to the truck by tightening two cap clamps under each of the three ends of the T-panel.

Place the clamps' bottom jaws in the track at each bedside and at the bulkhead. **For '16 and up Tacomas, the bottom clamp jaw will go under the square-tube bulkhead rail.** Uniformly tighten the cap clamps using a 9/16" socket to between **5-6 ft-lbs.**

**!** While tightening clamps, be aware of possible bed rail cap deformation. Overtightening clamps will damage bed rail caps and cause leaking.

**!** Retighten after a week of use. Check them every time you haul on top.

★ Removal of track mounted accessories can make installation smoother.

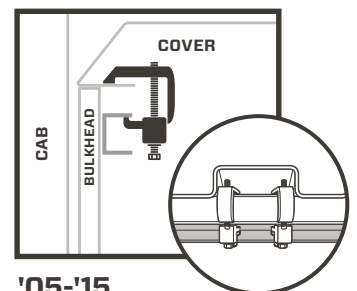

'05-'15  
TACOMA BULKHEAD  
CLAMPS INSTALLED

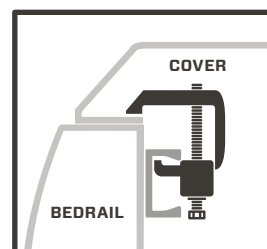

'05 AND UP  
BEDRAIL MOUNT

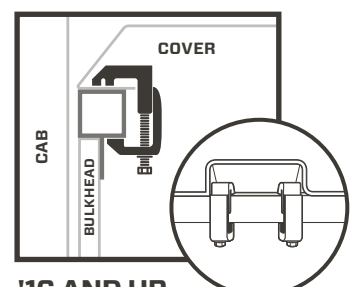

'16 AND UP  
TACOMA BULKHEAD  
CLAMPS INSTALLED

# ADJUST THE LOCK RODS

**8** Unbolt and move one of the bolts of the lock-rod guide brackets at the cab to the second, unoccupied slot using a 7/16" socket. Repeat this at each of the cover's bracket locations. All brackets should be in this orientation.

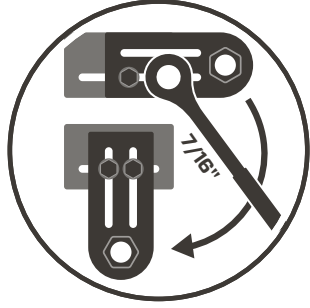

**9** Loosen the set screws for the tail and cab panel lock rods with the provided hex key and retighten each lock rod after ensuring the following...

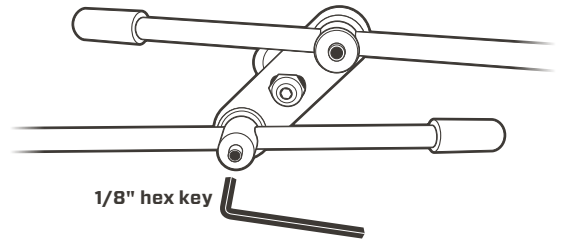

## '05-'15 CAB PANELS:

### CORRECT ORIENTATION

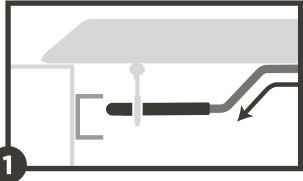

**1** The Z bend orientation is always maintained.

### + HANDLE OPEN

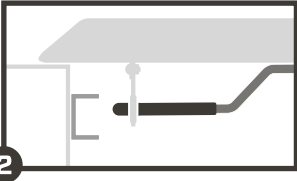

**2** With the lock handle in the open position, the rod tips just clear the track.

### ■ HANDLE CLOSED

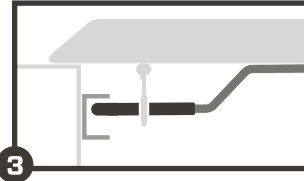

**3** With the lock handle in the closed position, the lock rods are fully inside the tracks and engaged as much as possible. Ensure the lock handle fully closes.

## '16 AND UP CAB PANELS:

### CORRECT ORIENTATION

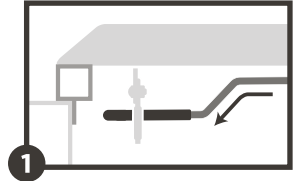

**1** The Z bend orientation is always maintained.

### + HANDLE OPEN

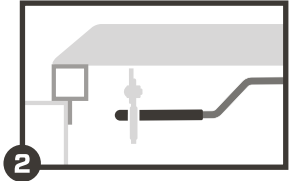

**2** With the lock handle in the open position, ensure the rod tips clear the bulkhead bar.

### ■ HANDLE CLOSED

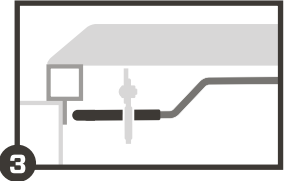

**3** With the lock handle in the closed position, be sure the lock rods land beneath the bulkhead bar and are engaged as far as possible.

## TAIL PANEL:

### CORRECT ORIENTATION

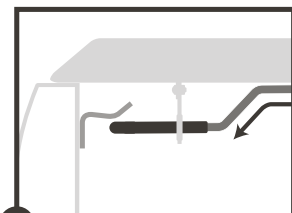

**1** The Z bend orientation is always maintained

### + HANDLE OPEN

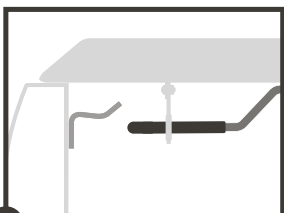

**2** With the lock handle in the open position, the rod tips just clear the striker brackets.

### ■ HANDLE CLOSED

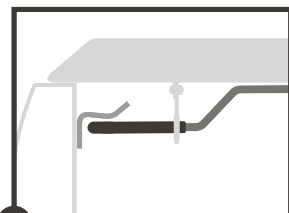

**3** With the lock handle in the closed position, the lock rods are fully under the striker brackets and engaged as much as possible. Ensure the lock handle fully closes.

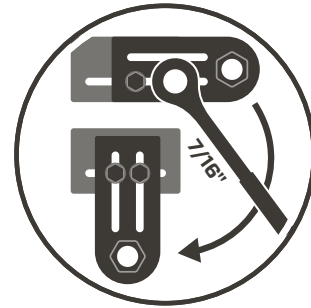

**10** After properly aligning the lock rods in the closed position, it is time to tighten all brackets using a 7/16" socket. To ensure a tight seal, it is crucial to simultaneously push up on the bracket AND apply downward pressure on the cover. Repeat for all bracket locations.

**!** The panels may be tough to open and close at first. Leave the panels closed as much as possible to allow the weatherstrip to break in. After a few days, you'll find things working smoothly.

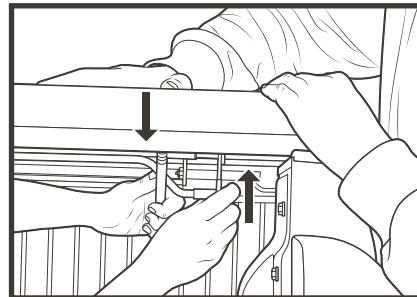

# ATTACH THE GAS SPRINGS

**11** Identify the 4 lighter gas springs and attach 2 to each **cab panel**.

**!** Make sure the barrel end is up. If you install your gas springs upside down, they'll fail.

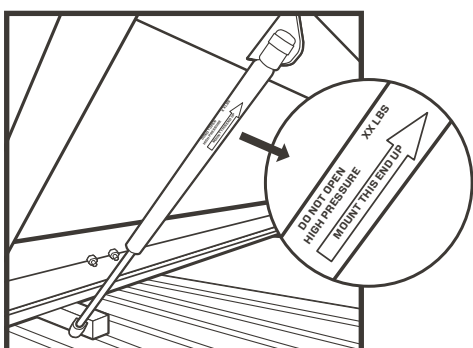
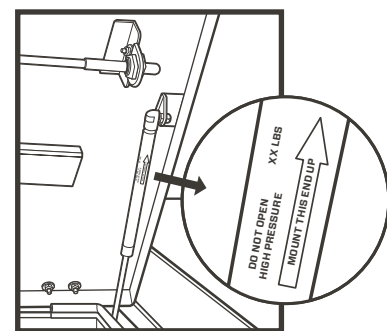

**12** Attach the 2 remaining gas springs on the **tail panel**, again making sure the barrel end is up.

**13** Leave the cover closed and locked for 24 hours to allow the pressure-sensitive weatherstrip adhesive to fully cure.

**24 hours**  
Adhesive cure time

**For first 2 weeks after installation**  
open tail panel on cover before operating tailgate.