



DIAMONDBACK



Install Video

INSTALLATION GUIDE

CVR-1

45 minutes
Normal install time

Keep an eye out for these icons:

IMPORTANT!
Important installation information

★ Helpful Hints
Tips to assist installation

PARTS INCLUDED:



Cab Panel



Center Panel

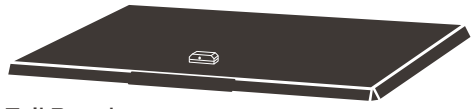

Tail Panel



Bed-Rail Edge Trim (4)



1/8" Hex Key

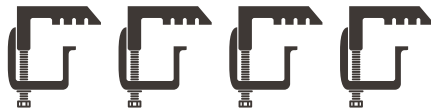

Cap Clamps (4)



Gas Springs (4)

TOOLS REQUIRED:



Ratchet Wrench,
(Torque Wrench preferred)



Utility Knife



9/16" Socket



7/16" Socket

PRE-INSTALLATION NOTES (REVIEW ALL OTHER INCLUDED INSTALLATION GUIDES BEFORE BEGINNING)



Most trucks require the **bulkhead weatherstrip** to be installed and some require additional bulkhead preparations. Please refer to the instructions in the **Bulkhead Prep Kit** prior to mounting the cover.

If your cover includes shims, affix the included bed rail shims first and reference their included instructions.

If you're installing a rear window protection accessory, mount it prior to mounting the cover.

MOUNT THE PANELS

1 Place the center panel across the bed, cheated toward the tailgate.

! Each panel is tapered front to back. Make sure the arrow on the underside of the panel is pointed toward the tailgate.

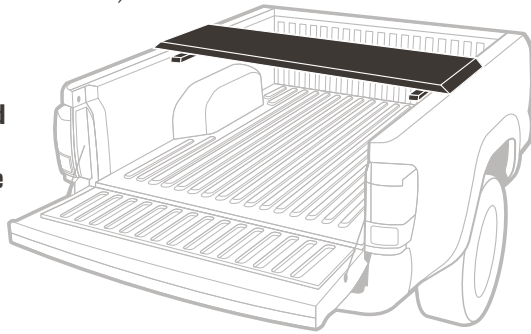

2 Attach the tail panel by holding it at a 90° angle from the bed rails and begin to mate the driver's side hinge first which is slightly longer.

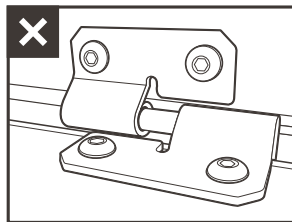
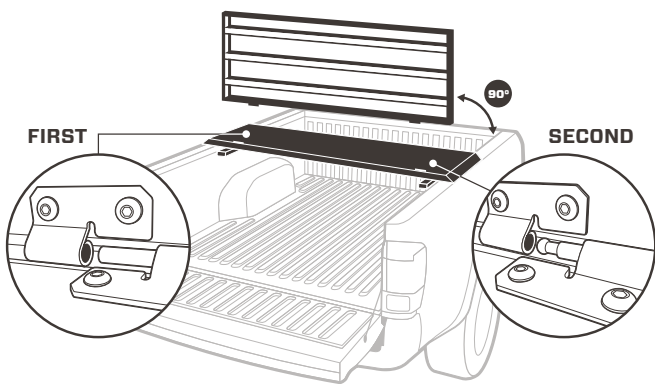

Partially mated hinge

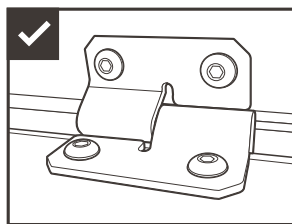

Fully mated hinge

★ Mating hinges is easiest when you engage the longer pin first.

3 In the same way, attach the cab panel by holding it at a 90° angle from the bed rails and begin to mate the passenger side hinge first which is slightly longer.

CAUTION! Be sure all hinges are fully mated before lowering panels.

4 Position the cover front to back so that the front of the cab panel lines up with the outside edge of the center of the bulkhead. Center the cover side-to-side on the truck.

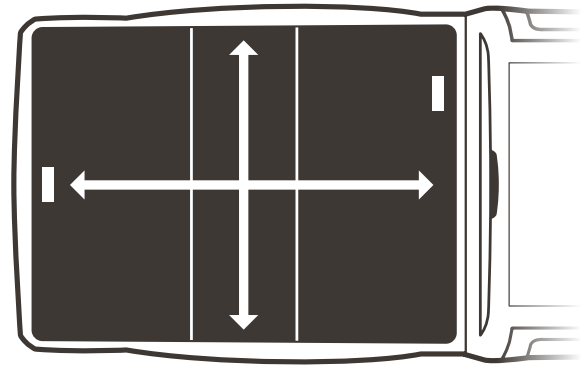

5 Position the cap clamps as far apart as possible under the center panel. Attach the center panel by uniformly tightening a cap clamp using a 9/16" socket to between **4-5 ft-lbs**.

! While tightening clamps, be aware of possible bed rail cap deformation. Overtightening clamps will damage bed rail caps and cause leaking.

! Retighten after a week of use. Check them every time you haul on top.

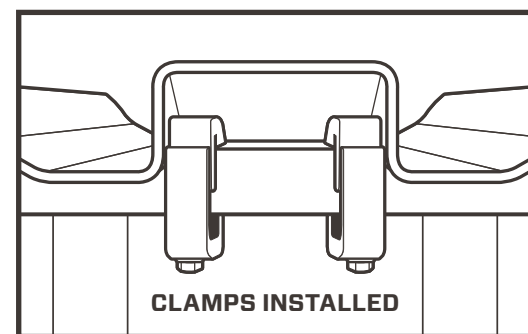

PREP FOR THE LOCK RODS

6 Unbolt and move one of the bolts of the lock-rod guide brackets to the second, unoccupied slot using a 7/16" socket. Repeat this on each of the cover's four brackets.

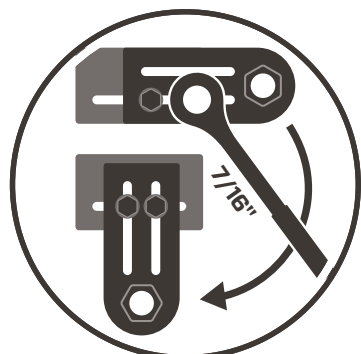

7 If your plastic bed rail cap extends below the metal edge of your bed rail, trim the excess at each lock rod location so that it's flush with the metal bed rail's edge.

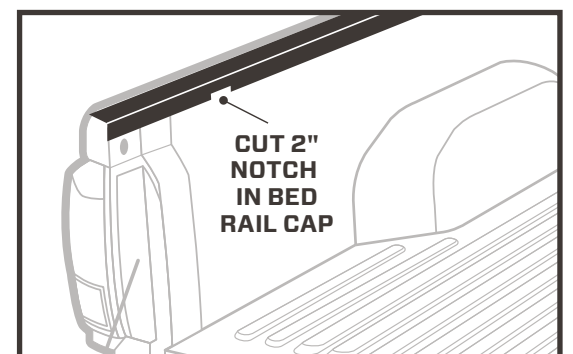

ADJUST THE LOCK RODS

8 Loosen the set screws for the tail and cab panel lock rods with the provided hex key and retighten each lock rod after ensuring **three things...**

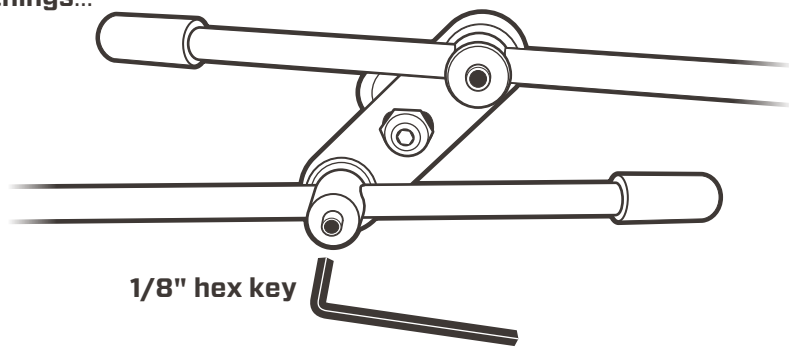

1/8" hex key

CORRECT ORIENTATION



HANDLE OPEN

HANDLE CLOSED

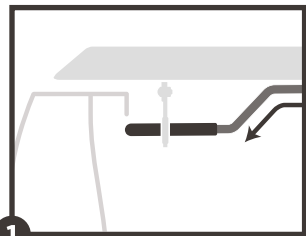

1 The Z bend orientation is always maintained

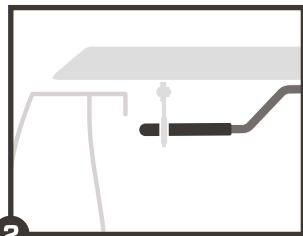

2 With the lock handle in the open position, the rod tips clear the bed rails.

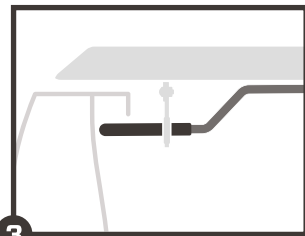

3 With the handle in the closed position, the rod tips do not hit the bed walls.

9 After properly aligning the lock rods in the closed position, it is time to tighten all brackets using a 7/16" socket. To ensure a tight seal, it is crucial to simultaneously push up on the bracket AND apply downward pressure on the cover. Repeat for all bracket locations.

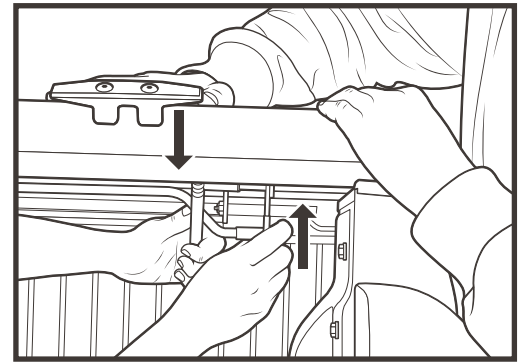

! The panels may be tough to open and close at first. Leave the panels closed as much as possible to allow the weatherstrip to break in. After a few days, you'll find things working smoothly.

★ The cab panel has a safety spring lock handle ensuring you engage the lock rods when closing the panel. This helps prevent accidental opening of the panel while driving.

! If you are installing a Cross Bin, do so now. Refer to the Cross Bin Installation Guide for details.

ATTACH THE BED RAIL EDGE TRIM

10 Peel the red adhesive backing from the edge trim pieces. Affix them to the metal bed rail in the correct orientation at the four points where the lock rods pass underneath.

★ Bed rail edge trim protects the lock rod end cap from wear, and helps draw the panels down and compress the weatherstrip. When installed properly, it will be a little tough to turn the lock handle at first.

★ Step 10 is unnecessary on '20-up Silverado & Sierra 2500 & 3500s and all '07-13 Silverados and Sierras.

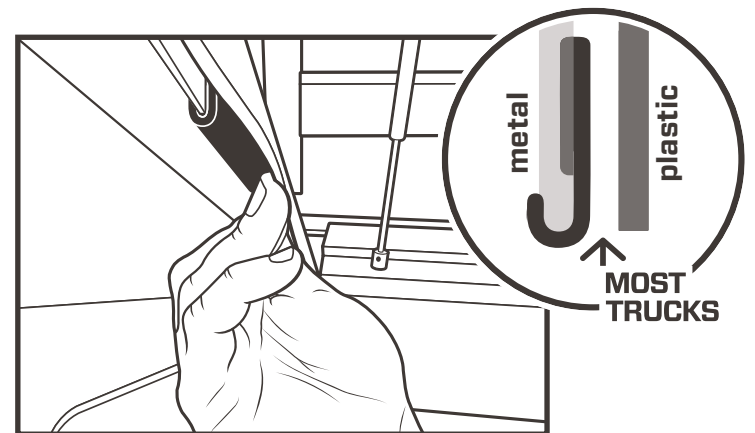

ATTACH THE GAS SPRINGS & SAFETY CATCH

11 Open the cab panel. Have a 2nd person support it in the open position. Loop the end of the cable tethers around the ball stud arms, making sure to go beyond the ball stud and nut.

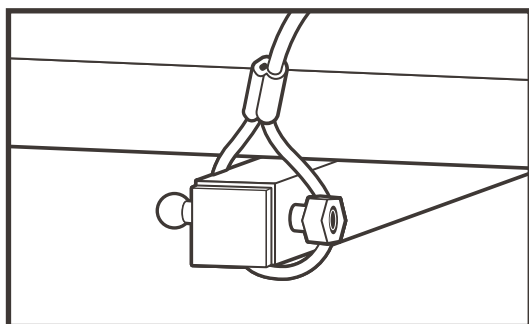

12 Attach 2 gas springs to the cab panel.

! Make sure the barrel end is up. If you install your gas springs upside down, they'll fail.

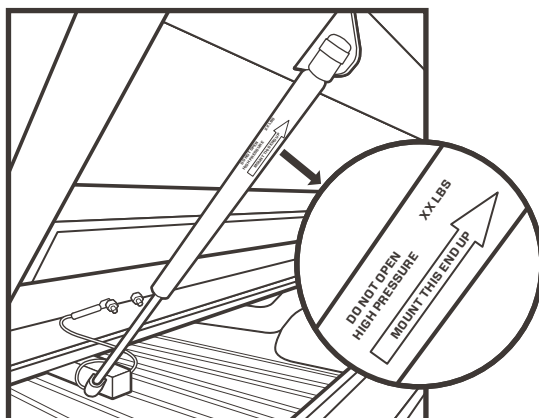

★ If 2 of your gas springs have heavier poundage printed on them, use them here.

13 Attach the safety catch by pulling down on the panel and pushing the keyhole at the bottom of the safety catch around the nut, making sure to engage the spring clip.

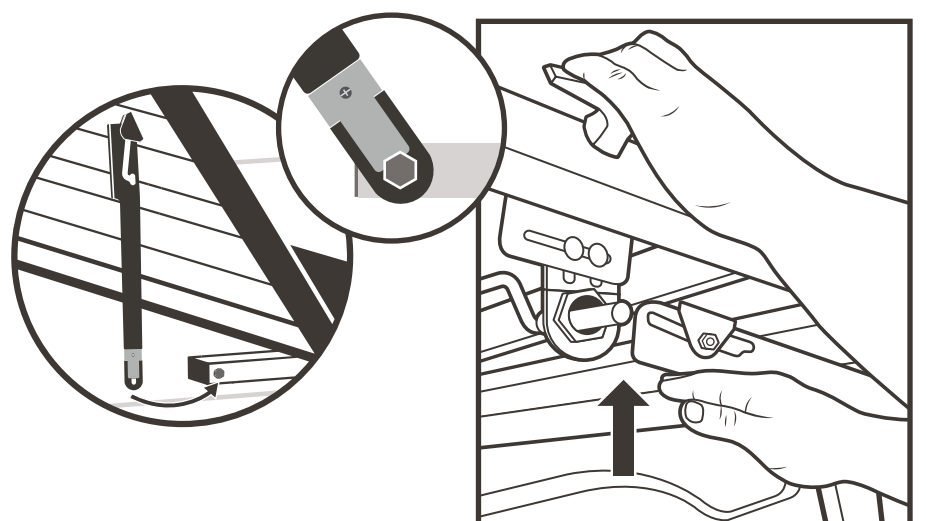

★ With the safety catch in place, your cab panel will only open partially. To fully open the panel, pull down while using your hand to push up on the flat part of the catch until it disengages.

14 Attach the 2 remaining gas springs on the tail panel, again making sure the barrel end is up.

15 Leave the cover closed and locked for 24 hours to allow the pressure-sensitive weatherstrip adhesive to fully cure.

🕒 24 hours
Adhesive cure time

📅 For first 2 weeks after installation
open tail panel on cover before operating tailgate.